

# SQUIRREL PERFORMING PALLETIZING SOLUTION

Discover the simplicity of Squirrel!  
Just provide us with the **weight, production rate, and size of your boxes**, and we'll deliver an instant, tailored solution.  
Effortless efficiency at your fingertips.



## Minimum effort, maximum result

**EDGE**<sup>TM</sup>  
GLOBAL SUPPLY

# The suitable solutions for your needs

Introducing **SQUIRREL**, the cutting-edge palletizing station engineered by the Mechatronic team at **MOTEK**. Elevate your working environment by seamlessly replacing manual palletizing with this state-of-the-art solution. Squirrel ensures **top-notch safety standards**, **minimizes** production layout space requirements, and boasts **user-friendly advanced technologies**. Experience enhanced flexibility, especially with one or more low-speed lines. Upgrade to Squirrel for a smarter and more efficient palletizing experience.

## TECHNICAL FEATURES

<b>WORKING MACHINE:</b>	8 cycles/minute
<b>BOXES FORMAT:</b> mm(inch)	min L=200(7.87) , P=200(7.87), H=200(7.87) max L=600(23.62) , P=400(15.75) , H=400(15.75)
<b>PALLETIZATION FORMAT:</b> mm(inch)	
<i>Pallet:</i>	800(31,49) x 1200(47,24) 1000(39,37) x 1200(47,24) 800(31,49) x 600 (23,62)
<i>Max height:</i>	2000mm (74,78)
<i>Max box weight:</i>	16 Kg (35,27 lbs)

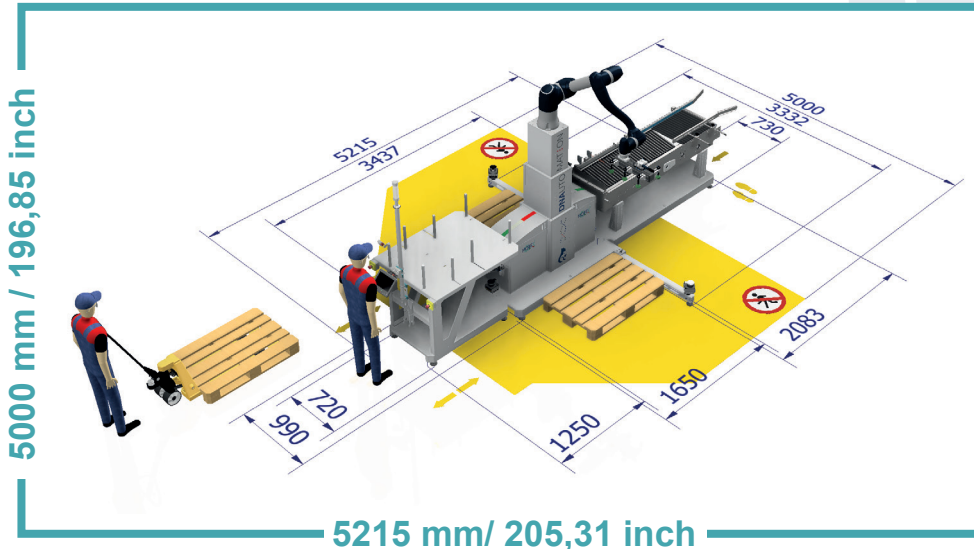
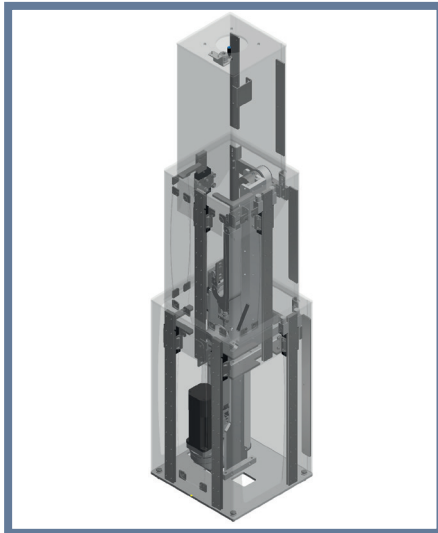

## PRODUCTIVITY

Integrated **Seventh Axis**  
Several Lines up to **2000 mm palletised height**

## EASY TO USE

Software **Fully Configurable** without technical skills

## CERTIFICATIONS

**UL 508-A USA**  
**CSA 22-2 N°14 CANADA**  
**European Machinery Directive (2006/42 / CE)**

## FLEXIBILITY

Easily transportable with a **common pallet truck**