

SQUIRREL PERFORMING PALLETIZING SOLUTION

Discover the simplicity of Squirrel!
Just provide us with the **weight, production rate, and size of your boxes**, and we'll deliver an instant, tailored solution.
Effortless efficiency at your fingertips.

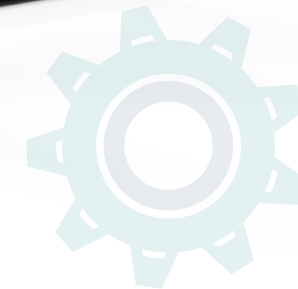

Minimum effort, maximum result



SQUIRREL

The suitable solutions for your needs

Introducing **SQUIRREL**, the cutting-edge palletizing station engineered by the Mechatronic team at **MOTEK**. Elevate your working environment by seamlessly replacing manual palletizing with this state-of-the-art solution. Squirrel ensures **top-notch safety standards**, **minimizes** production layout space requirements, and boasts **user-friendly advanced technologies**. Experience enhanced flexibility, especially with one or more low-speed lines. Upgrade to Squirrel for a smarter and more efficient palletizing experience.

TECHNICAL FEATURES

WORKING MACHINE:	8 cycles/minute
BOXES FORMAT:	min L=200, P=200, H=150 mm max L=600, P=450, H=450 mm
PALLETIZATION FORMAT:	
<i>Pallet:</i>	1200mm x 800mm 1200mm x 1000mm 600mm x 800mm
<i>Max height:</i>	2400mm
<i>Max box weight:</i>	24 Kg

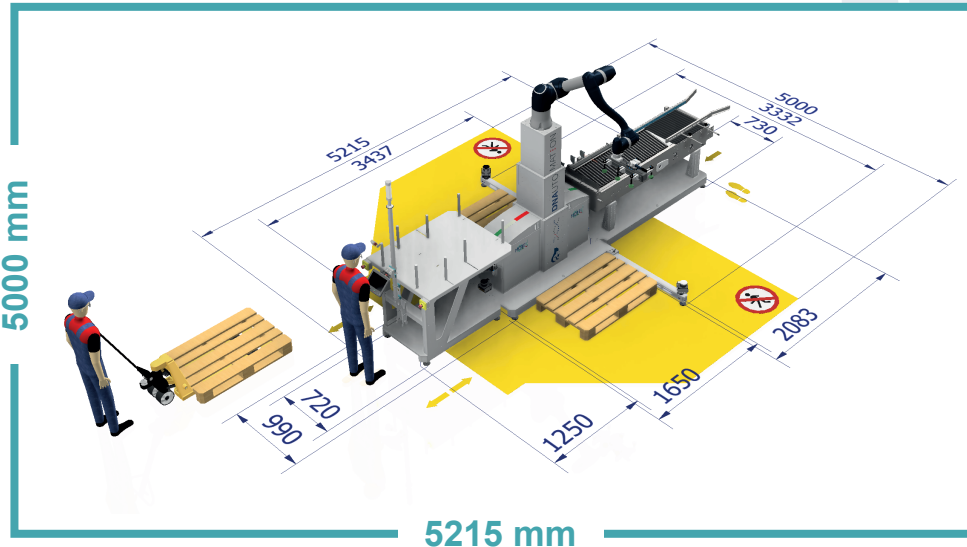
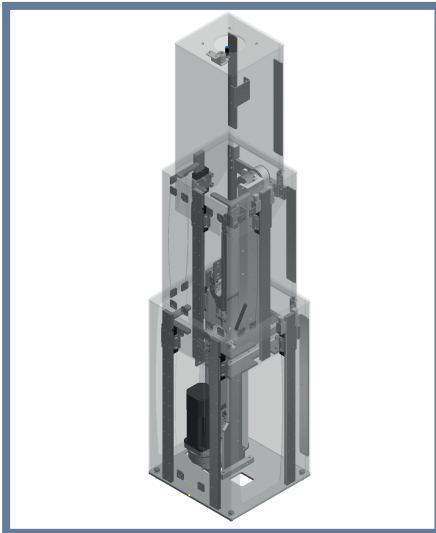

PRODUCTIVITY

Integrated **Seventh Axis**
Several Lines up to **2400 mm palletised height**

EASY TO USE

Software **Fully Configurable** without technical skills

CERTIFICATIONS

UL 508-A USA
CSA 22-2 N°14 CANADA
European Machinery Directive (2006/42 / CE)

FLEXIBILITY

Easily transportable with a **common pallet truck**



info@squirrelpalletizer.com